

BEGA

95 044

Fahrradständer für den Objektbereich
 Bicycle stand for non-residential areas
 Supports à vélo pour la zone du projet

Montageanleitung

Installation instructions

Notice de montage

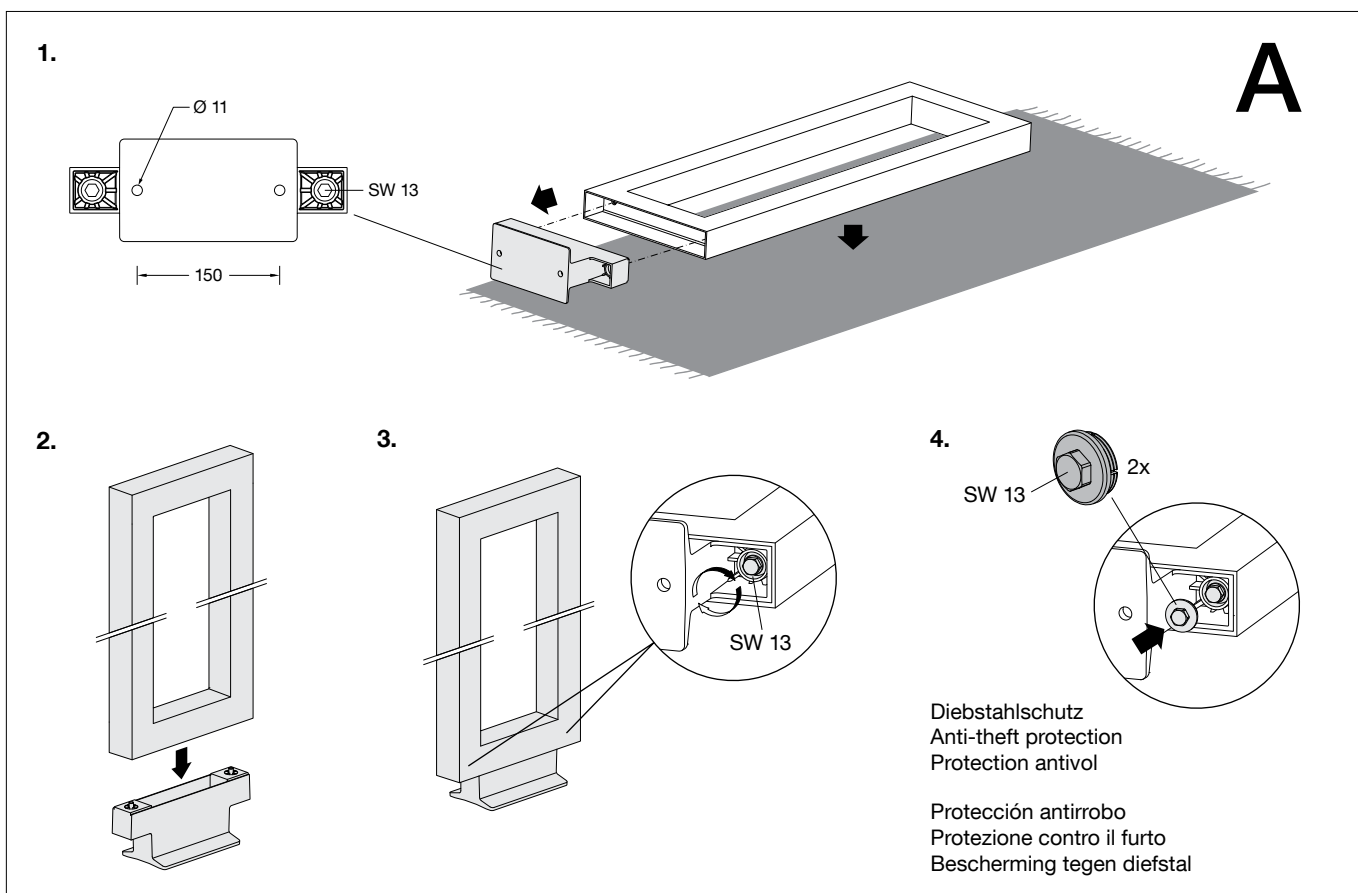
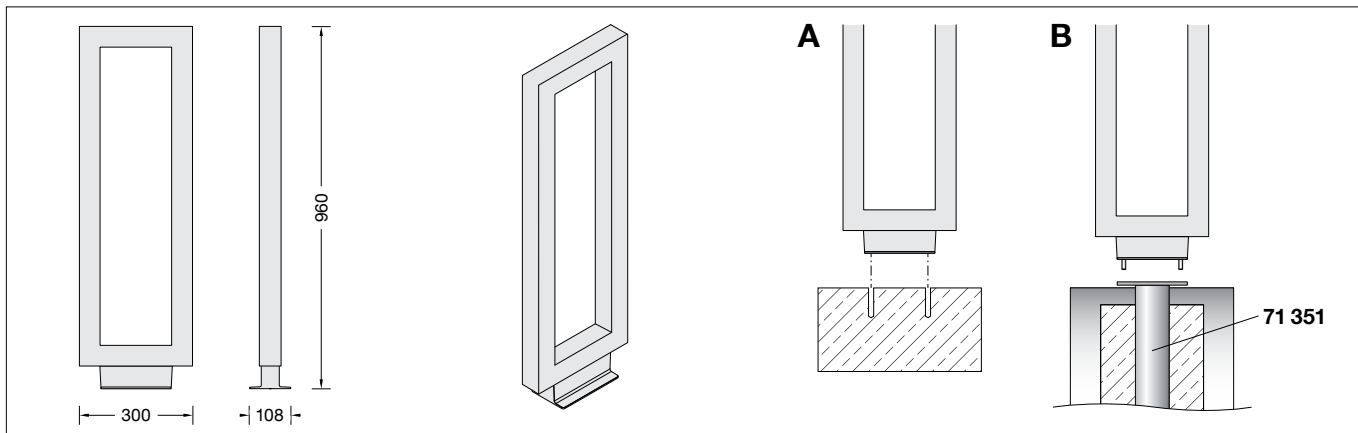

Bitte beachten:
 Das Befestigungsmaterial ist bauseits festzulegen und zu stellen: z. B. Stein-
 schrauben aus Edelstahl DIN 529.
 Dabei auf bauaufsichtliche Zulassung
 achten.

Bitte beachten:
 The fixing material must be determined
 and provided by the customer: e.g. stone
 bolts made of stainless steel DIN 529.
 Note authorization through supervision of
 construction.

Attention :
 Les matériaux de fixation doivent être
 définis et fournis sur le chantier: par exem-
 ple vis à scellement en acier inoxydable
 DIN 529.
 Respecter les consignes de la maîtrise
 d'ouvrage.

B

1.

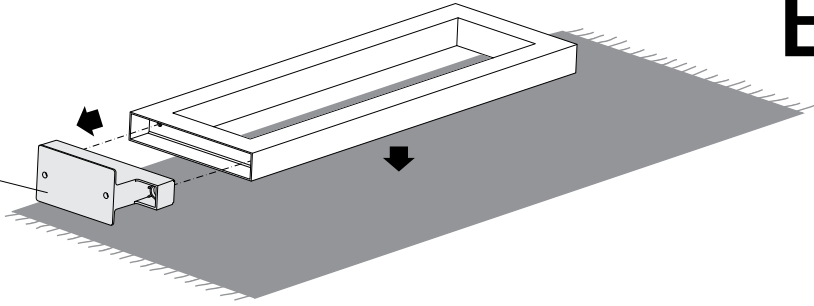
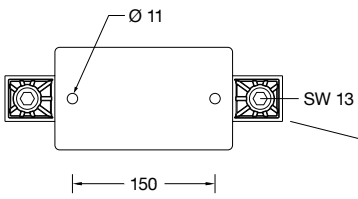

2.

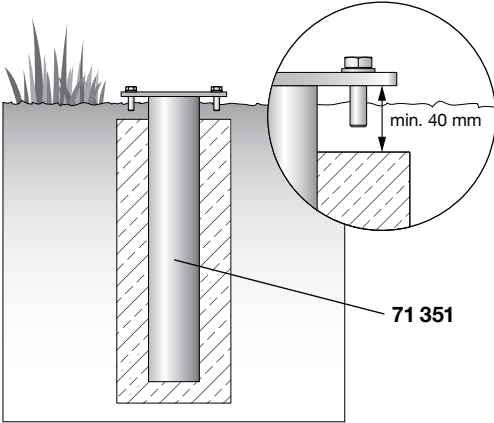

3.

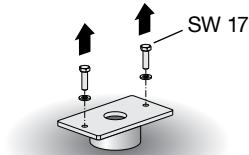

4.

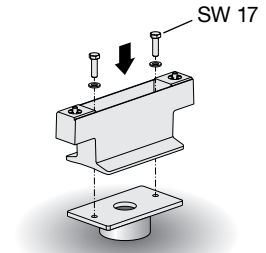

5.

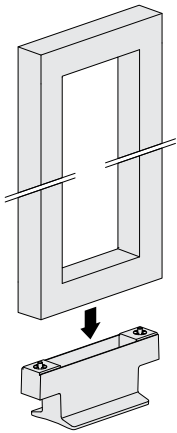

6.

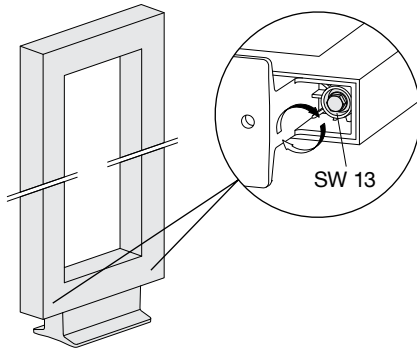

7.

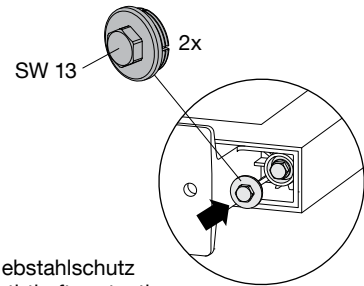

Diebstahlschutz
Anti-theft protection
Protection antivol

Protección antirrobo
Protezione contro il furto
Bescherming tegen diefstal